

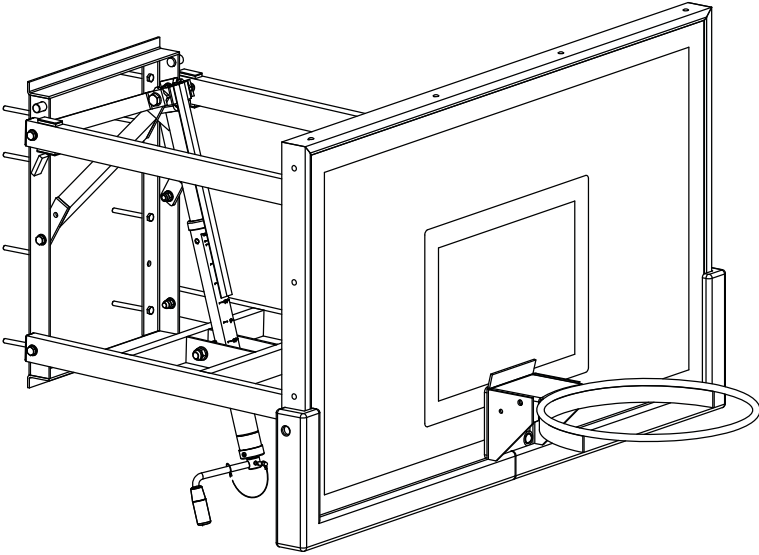

WM54 WM60 WM72

*ADJUSTABLE HEIGHT
WALL MOUNT SYSTEM*

Version 3



*Installation
& Owner's
Instructions*





SAFETY INSTRUCTIONS

FAILURE TO FOLLOW THESE WARNINGS MAY RESULT IN SERIOUS INJURY AND/OR PROPERTY DAMAGE.

FAILURE TO DO THESE SAFETY INSTRUCTIONS MAY RESULT IN SERIOUS INJURY, PROPERTY DAMAGE AND WILL VOID WARRANTY.

Owner must ensure that all players know and follow these rules for safe operation of the system.

To ensure safety, do not attempt to assemble this system without following the instructions carefully. Proper and complete assembly, use and supervision is essential for proper operation and to reduce the risk of accident or injury. A high probability of serious injury exists if this system is not installed, maintained, and operated properly.

If use a ladder during assembly, use extreme caution.

2 or 3 people are recommended for this operation.

Locate your system away from potential dangers, including trip hazards, high-traffic areas or where a vehicle might contact with system.

Do not locate the system under power line that may come into contact with the system as it is raised. Power line should not be within 20ft. radius of system

Climate, corrosion or misuse could result in system failure.

If technical assistance is required, contact us:



WARNING

FAILURE TO DO THESE WARNINGS MAY RESULT IN SERIOUS INJURY AND/OR PROPERTY DAMAGE.

Owner must ensure that all players know and follow these rules for safe operation of the system.

Only hang from the rim briefly to regain balance or avoid injuring others.

Release the rim as soon as possible safely.

During play, especially when performing dunk type activities, keep player's face away from the backboard, and net. Serious injury could occur if teeth/face come in contact with backboard, rim, or net.

Do not use the system to lift anything. When adjusting height, keep hands and fingers away from moving parts.

Do not allow children to adjust system. During play, do not wear jewelry (rings, watches, necklaces, etc.) Objects may entangle in net.

Keep water and organic material away from system. System can rust and fail.

Check all metal parts regularly for rust. Completely remove the part which is

rust and repaint with exterior enamel. If rust has penetrated any steel parts, replace that part immediately.

Check system before each use for loose hardware, signs of rust and

instability. Repair before each use.

Never play on damaged equipment.

Wear a mouthguard when playing to avoid dental injuries.

Frame Attachment

A measure, level, drills and wrenches may be needed during assembly.

- 1. Determine where to place frame on mounting surface.**
The frame is 28" x 21" (HXW). The frame holes are 16" on center.
Use a level to make drawing the horizontal line easier.
- 2. Draw a horizontal line at least 21" on the mounting surface**
that is 87" up from the playing surface.
- 3. Unpack the frame.** Lay aside extension arms, mounting brackets.
- 4. Position and center frame bottom on the horizontal line**
with the frame's safety rod at the top.
- 5. Level frame horizontally and vertically using a level.**
Mark the mounting holes needed for attachment of frame.
- 6. Drill appropriate size holes as needed in mounting surface**
based upon type of wall fastener being used by customer or installer.
- 7. Loosely attach frame to mounting surface** using correct fasteners (8pcs-4" Hex Lag included in the pack).
- 8. Level frame horizontally and vertically** using a level and appropriately tighten fasteners.

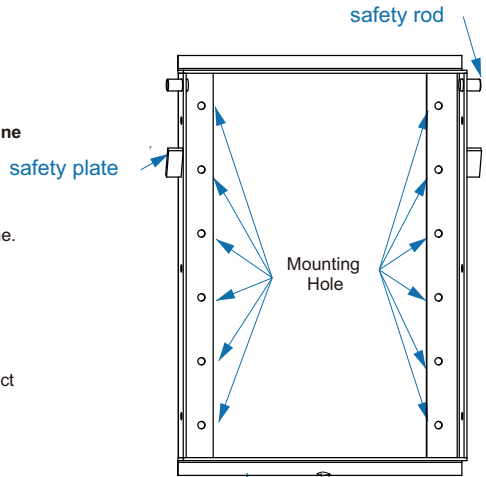

IMPORTANT

- Bottom of frame should be 88" up from playing surface. This is needed to achieve full range of system height adjustability.
- Wall hanging location is the responsibility of the customer and/or installer.
- It is the responsibility of the customer and/or installer to determine how many of the frame's 12 mounting holes must be used to safely secure the wall mount system for play.
- Fasteners to be determined and provided by the customer and/or installer.

playing surface

87"

Final Attachment

1. Attach rim to Backboard.

Attach Rim Pad (#1) to Glass as shown in right photo. Remove the Rim box cover, put Rim against Rim pad, secure it with 4 Carriage bolts M10x55 (#2), 4 Flat washers M10 (#3), 4 Flange nuts M10 (#4) and 4 mounting sleeves (#5). See Figure 9 .

Tighten all four bolts and nuts completely.

Put Rim box cover back and secure it with removed screws.

**Note: Tighten all four bolts and nuts completely.
Put Rim box cover back and secure it with removed screws.**

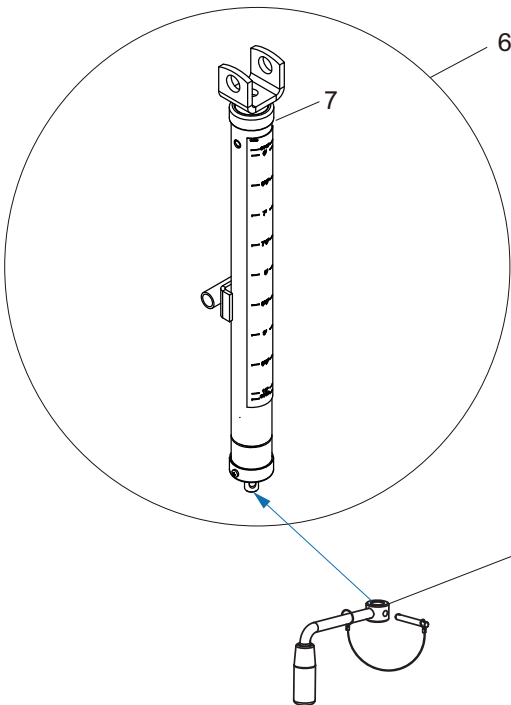
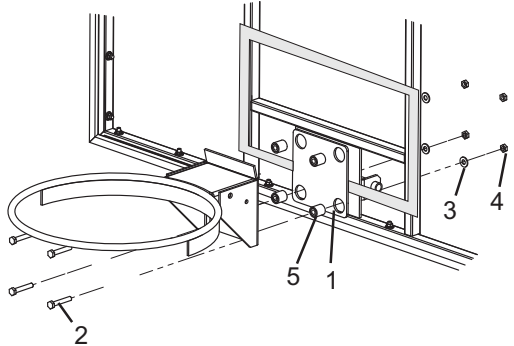

Apply Rim Height Sticker

Use a tape measure to crank rim up to exactly 10' from playing surface. Make a line mark on the Actuator (#6) against upp edge of Actuator Sleeve (#7). Crank the rim all the way down to the extreme end. Peel and apply Rim Height sticker to outside of Actuator (#6) lining up the mark with the 10' mark on the Rim Height Sticker. See Detail on left hand.

Attach crank to the bottom of the actuator, secure it with attached pin.

Ryval Warranties

Buyer agrees that products sold by Ryval hoops carry the following warranty. Subject to proper installation and normal, intended use, all structural components of Coach Series tm, Phenom X Series tm, Wall Mount Hoops are warranted to the original owner to be free of defects in materials and workmanship for the duration of ownership (Limited Lifetime) by the original retail purchaser, subject to the limitations below. The Driveway Series tm will be covered by this warranty for a period of 5 years. This limited warranty coverage is extended only to the original retail purchaser and terminates if the original retail purchaser otherwise transfers or sells the product. This warranty is limited to a repair or replacement of the defective part. Product covered under this warranty will be shipped at the customer's expense. Ryval Hoops is not responsible for any expense associated with freight, or delivery and installation of the warranted part(s). Ryval Hoops reserves the right to inspect all warranty claim parts for which a claim has been made.

Any modification could damage the structural integrity of the equipment and voids all warranties. Where listed as "Limited", the warranties shall cover damage or failure that occurs during the course of normal or intended use of the product. Normal or intended use shall be described as activity that is necessary for the participation in the sport for which the equipment is designed. Not covered is damage caused by deliberate hanging, multiple player hanging, vandalism, non-basketball activities or any other activity that could be regarded as abusive.

Padding Warranty: Multi-Purpose Backboard Edge Padding: One-year limited warranty.
Custom fit & Wrap around Pole Padding & Gusset Padding One-year limited warranty.

Net: One-year limited warranty

Not Covered By This Warranty

- Any Products subjected to abuse, negligence, improper installation, vandalism, acts of God, alteration of product or any other events beyond the control of Ryval Hoops.
- Use in non-residential applications of glass backboards.
- Paint or rusted parts. If rust begins, sand rust & loose paint, primer & paint with a satin black. Touch-up kits are available.
- Deterioration of product due to time or wear and tear.
- Use in non-residential applications of Glass backboards.

Normal deterioration of products due to atmospheric conditions, weather, rust wear and tear (including paint), or other causes that do not affect functional use are not covered by Ryval Hoops warranties. All warranties are valid only when product is used in the intended application and when installed according to Ryval Hoops instructions. Warranty will be void if maintenance instructions in the owner's manual are not followed, including jack lubrication. If you did not receive an owner's/instruction manual, please contact Ryval Hoops and one will be sent to you.

Warranty Claims: A copy of the original invoice must be presented to initiate warranty claim. A warranty claim form must be completed and photos submitted for any item you wish to claim under warranty. If part to be warranty is requested, a “Return Merchandise Authorization” (RMA) number will be required prior to shipping damaged Product by original retail Consumer Purchaser with freight prepaid by consumer. If the purchase was made through a dealer, warranties do not cover dealer service charges, labor charges, freight or travel expense associated with replacement, repair or removal or warranty item

-This warranty is exclusive and expressly in lieu of all other warranties, expressed or implied, including warranties of merchantability or fitness for use. Ryval Hoops does not assume, or authorize any person to assume for us, any other liability in connection with the sale of our products. If Ryval Hoops cannot disclaim or exclude implied warranties under applicable law, then to the extent possible any claims under such implied warranties shall expire or expiration or the applicable warranty period. Some states do not allow limitations on how long an implied warranty lasts, so the above limitation may not apply to you, Ryval Hoops does not assume or authorize any person to assume for us, any other liability in connection with the sale of our products. Ryval Hoops shall not be liable for loss of use of the product or other consequential or incidental costs. Expenses or damages incurred by the consumer or any other use. To the maximum extent permitted by law, Ryval Hoops assumes no responsibility for incidental or consequential damages, which may arise from the purchasers or use of our equipment. Some states don not allow the exclusion or limitations of incidental or consequential damage, so the limitation or exclusion may not apply to you. If any provision of this warranty is invalid, void or unenforceable in any instance or respect, the unenforceable provision will be severed and reformed to affect the intent of this limited warranty to the maximum extent possible, and the remaining provisions shall continue in full force and effect and shall be enforced to the full extent permitted by law.

Ryval Hoops reserves the right at any time to change product specifications or substitute similar components. A limited lifetime warranty is effective for the duration of ownership by the original retail purchaser or 5 years after discontinuation of the product by Ryval Hoops.

This warranty gives you specific rights and you may also have other rights, which vary from state to state.

Questions or Comments?

www.RyvalHoops.com

Email: info@ryvalhoops.com

Phone 800-787-0655